



FARR 40 AUSTRALIAN CHAMPIONSHIP 2010

FRIDAY 12TH – SUNDAY 14TH MARCH 2010

SAILING INSTRUCTIONS

1 RULES

- 1.1 The regatta will be governed by the “rules” as defined in the 2009 - 2012 ISAF Racing Rules of Sailing (RRS), Yachting Australia Special Regulations Part 1 Category 4 and the Farr 40 Class Rules, except as any of these are changed by the sailing instructions.
- 1.2 RRS 44.2 is amended in that only one turn, including one tack and one gybe, is required except for infringements that occur within three boat lengths of a rounding mark.
- 1.3 All boat shall display the supplied sponsors event bow signage, boom decals and backstay flags, if provided, from the start of the first race until the end of the regatta.
- 1.4 The race committee may carry out random checks for compliance of Rules as noted in 1.1 at any time during the regatta.
- 1.5 RRS 51 is amended by addition of the following sentence. “The maximum amount of drinkable liquid aboard each yacht shall not exceed 6 litres per person.”
- 1.6 Where Farr 40 Class Rule 25.0 applies, the Class Administrator will act as ‘class representative’

2 REGISTRATION AND WEIGH-IN

- 2.1 Registration and Weigh-in will take place from 0800 to 0900 on Friday 12th March at Royal Sydney Yacht Squadron. Alternative weigh-in times no earlier than Thursday 11th may be advised by the Organising Authority or Class representative..

3 NOTICES TO COMPETITORS

- 3.1 Notices will be posted on the official regatta notice board located at RSYS.
- 3.2 VHF channel 69 shall be used as the Race Communications channel.
- 3.3 The Race Committee may broadcast race information before and during each race. Any such communication shall not be deemed as outside help. This Alters RRS 41.

4 SIGNALS MADE ASHORE

- 4.1 Signals made ashore will be displayed on the flagstaff, located in front of the clubhouse.
- 4.2 Code flag "AP" with two sound signals (one when lowered) when displayed ashore means "Races not started are postponed". The Warning Signal will not be made less

than 30 minutes after the “AP” is lowered ashore. This Alters RRS Race Signals

5. CHANGES TO SAILING INSTRUCTIONS

- 5.1 Changes to the sailing instructions made ashore will be posted before 0900 hrs on the day they shall take effect.
- 5.2 Changes to the Sailing Instructions made afloat will be indicated by the display of Code Flag 3rd Substitute accompanied by two sound signals. The change may be communicated either orally or in writing.

6. SCHEDULE OF RACING

- 6.1 The regatta will consist of a maximum of nine (9) Windward/Leeward races.

Date	Location	Event	Warning Signal
Friday 12 th Mar	Macquarie Circle	Up to 4 W/L races	1055 hrs
Saturday 13 th Mar	Macquarie Circle	Up to 4 W/L races	1055 hrs
Sunday 14 th Mar	Macquarie Circle	Up to 4 W/L races	1055 hrs
Sunday 14 th Mar	RSYS	Presentation of Prizes	Asap after racing

- 6.2 The last time for a warning signal Sunday 14th will be 1530 hrs

7 RACING AREA

- 7.1 The Racing Area will be on the waters of Port Jackson and the Tasman Sea and will be indicated by a Notice posted by 0900 hrs on the Official Notice Board each day.

8 MARKS

- 8.1 Mark 1 and the Gate marks will be orange conical buoys.
- 8.2 Mark 1a will be an orange cylindrical buoy.
- 8.3 The start / finish mark will be a black and white cylindrical buoy.
- 8.4 The change mark(s) as per SI 12, shall have a black band.

9. THE COURSE

- 9.1 The courses will be windward / leeward.
- 9.2 A board displaying the course and approximate compass bearing to Mark 1 will be displayed by the Race Committee Boat.
- 9.3 Mark 1 will be laid to windward of the start line. Mark 1a will be laid to port of Mark 1.
- 9.4 The Gate will be laid approximately 50 metres to windward of the starting line. (Note: The Gate may be laid after the starting signal)
- 9.5 Boats shall sail between the Gate marks from the direction of the previous mark and round either Gate mark. If only one Gate mark is set, boats shall round the mark to port.

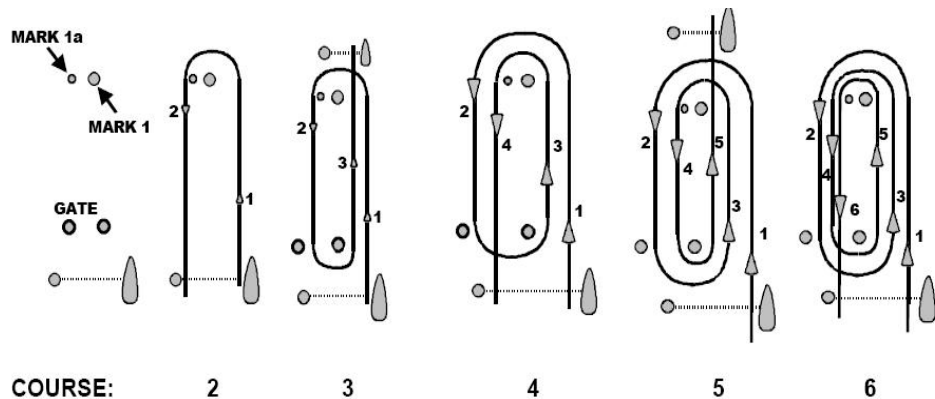

COURSE SIGNAL	COURSE CONFIGURATION All Marks rounded to PORT
2	Start – 1 – 1a – Finish (Downwind)
3	Start – 1 – 1a – Gate –Finish (Upwind)
4	Start – 1 – 1a – Gate – 1 – 1a – Finish (Downwind)
5	Start – 1 – 1a – Gate – 1 – 1a – Gate – Finish (Upwind)
6	Start – 1 – 1a – Gate – 1 – 1a – Gate – 1 – 1a – Finish (Downwind)

10 THE START

- 10.1 The Class Flag will be International Code Flag “W”.
- 10.2 Will be between the Start / Finish Mark and the flagstaff displaying an orange flag on the Race Signal Vessel.

11 RECALLS

- 11.1 In addition to RRS 29, the Race Committee MAY call boats on channel 69.

12 CHANGING AND SHORTENING THE COURSE

- 12.1 When changing the position of the next mark, the race committee will lay a change mark(s). Any subsequent marks may be relocated to maintain the original course configuration. Further changes of that mark will revert to the original mark(s).

13 FINISH LINE

- 13.1 Will be between the Start / Finish mark and the flagstaff displaying an orange flag on the Race Signal Vessel. The Start / Finish mark may be relocated closer to the Race Signal Vessel after the start.

14 TIME LIMIT

- 14.1 The time limit for all races is 2 hours from the start, or within twenty five minutes of the first boat to finish, whichever is the earliest.

- 14.2 Boats not finishing within the time limit will be scored points equal to the number of boats finishing within the time limit plus two points, but no more points than the number of starters. This changes RRS 35, A4.2 and A5.

15 PROTESTS

- 15.1 Submission of Protests:
Protests in accordance with RRS 61 will be delivered to the RSYS Sailing Office within 1.5 hours after the finish time of the last boat. (in the last race of the day when multiple races are conducted).
- 15.2 Hearing of Protests:
Protests may be heard in approximately the order of receipt as soon as possible and notified at the time of lodgement of the protest.
- 15.3 Reopening a Hearing:
RRS 66 is changed by adding: “On the last day of racing, a party to the hearing may ask for a reopening no later than half an hour after being informed of the decision.”
- 15.4 In accordance with RRS 64.1(a) the protest committee may make any determination it decides is equitable for the fleet.

16 ARBITRATION

- 16.1 At the option of the protest committee a short arbitration hearing may be heard prior to a protest hearing (affecting RRS 63). After the written protest form is properly lodged, one representative from each boat shall meet with the arbitrator, no witnesses will be allowed. Protests not resolved by arbitration will be lodged with the Protest Committee.
- 16.2 Boats that accept fault at an arbitration hearing shall be penalised by having her race score increased by a 40% scoring penalty calculated as stated in rule 44.3(c) but not more than a DSQ. All other boats scores will remain the same. Once accepted by all parties, this decision is not subject to reopening or appeal and the protest shall be withdrawn. This alters RRS 60.1, 62 and 66.

- 16.3 The arbitrator may be a member of any subsequent Jury or Protest Committee.

17 SCORING

- 17.1 The 2010 Farr 40 Australian Championship shall consist of a maximum of nine (9) races. The minimum races to constitute a series shall be four (4).
- 17.2 The Low Point scoring system, Appendix A of the RRS shall apply except all races will count for total points.

18 PRIZES AND TROPHIES

- 18.1 Prizes will be awarded to each yacht placing first, second and third in the regatta. Prizes will also be awarded daily to the Boat of the Day. The Australian Champion Perpetual Trophy will be awarded to the overall winner.